

SEE 1002 FOR HOLE LOCATIONS (TYP)

SIDE ELEVATION
SCALE: 1/2"=1'-0"

NOTES:

- 1. FLAT EXPANDED MESH USED TO MINIMIZE INJURIES TO THE BEARS CLAWS OR TEETH. DO NOT SUBSTITUTE ANY OTHER MESH.
- 2. CAGE BODY TO BE CONSTRUCTED OF TWO 4' X 8' SHEETS OF STEEL PLATE,(14 GAUGE TOP, 12 GAUGE BOTTOM), AND TWO 39"x 8' SHEETS OF 1/2" #13 F FLAT EXPANDED METAL SHEET.
- 3. UNLESS NOTED OTHERWISE ALL WELDS SHALL BE 1/4" FILLET WELDS.
- 4. ALL WELDING SHALL CONFORM TO CSA W59-M AND BE PERFORMED BY WELDERS CURRENTLY QUALIFIED UNDER CSA W59-M.

* SEE DRAWING 1003 FOR ITEM DETAILS, AND 1004 FOR ITEM NUMBER DESCRIPTIONS.

	PROJECT CAMBRIAN DESIGN BEAR TRAP	
	DRAWING TITLE SIDE ELEVATION	
NORTHWEST REGION ENGINEERING SERVICES	SCALE AS SHOWN	DATE JAN.10/05
	DWN. BY BCD	CHKD. BY KCB
	DWG. No. 1001	REV. 0

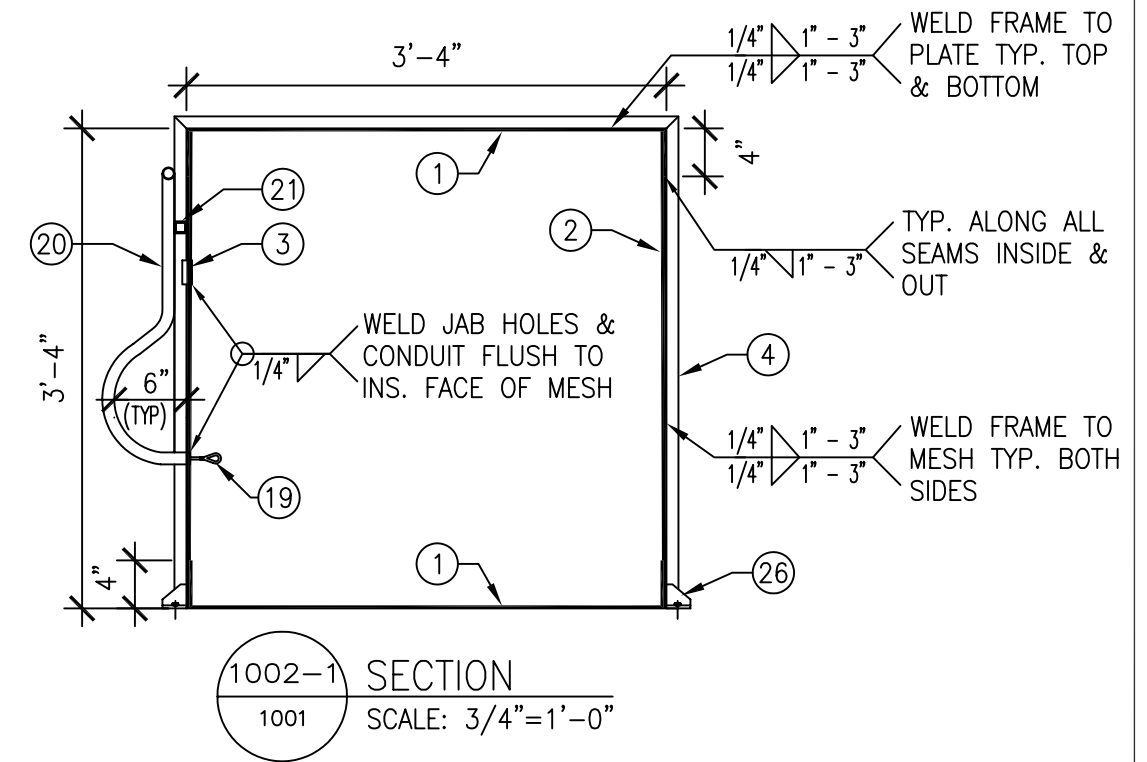
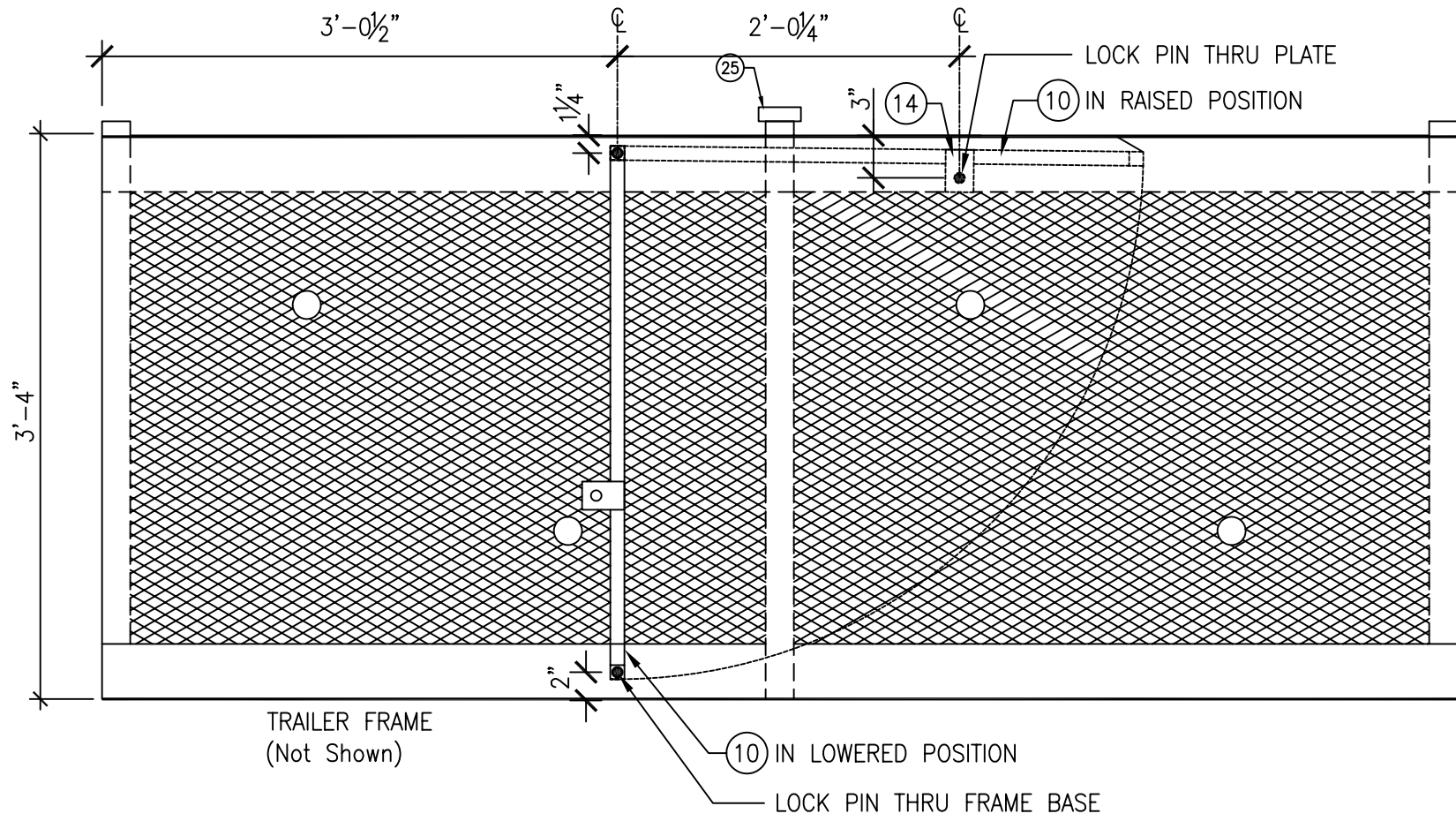
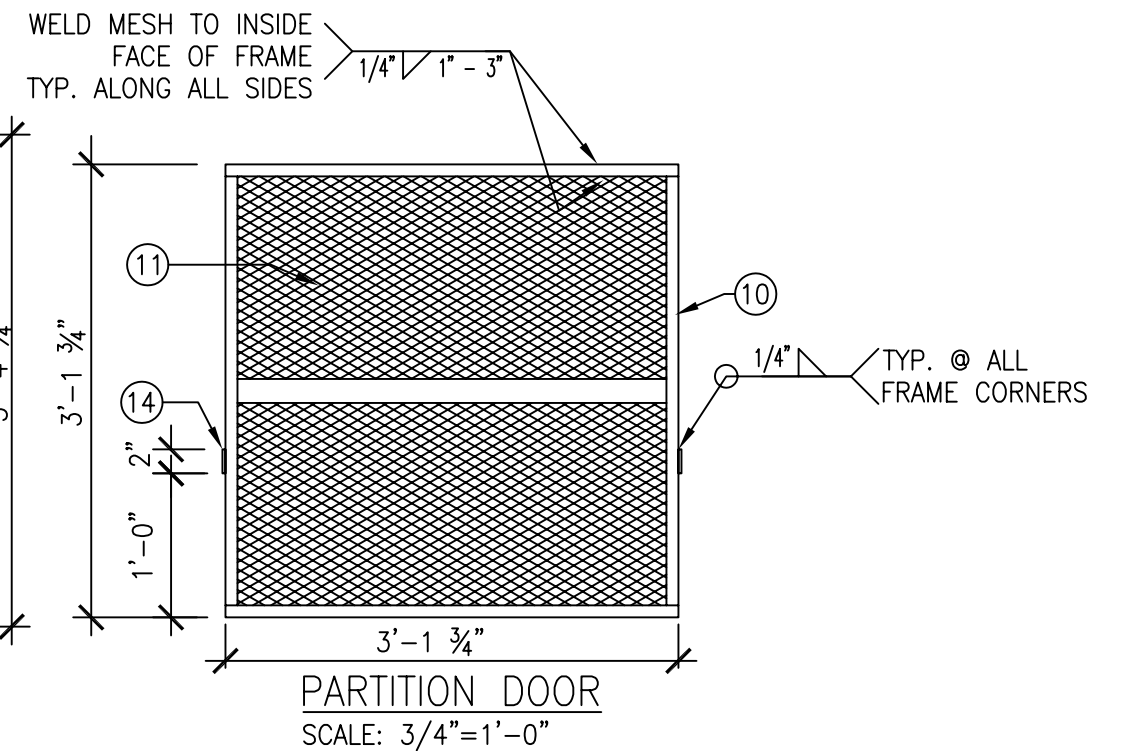
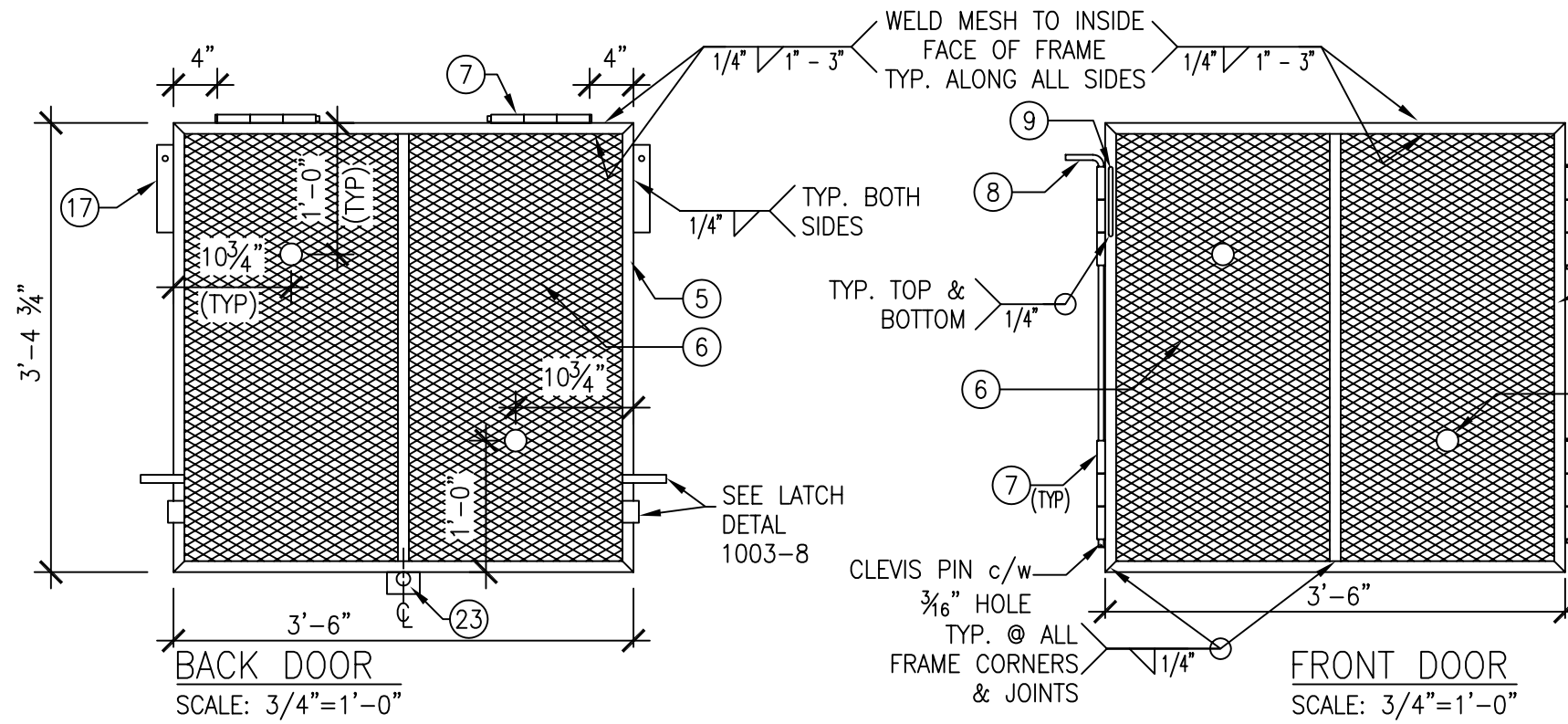

* SEE DRAWING 1003 FOR ITEM DETAILS, AND 1004 FOR ITEM NUMBER DESCRIPTIONS.

	PROJECT CAMBRIAN DESIGN BEAR TRAP		
	DRAWING TITLE DOOR ELEVATIONS & SECTIONS		
NORTHWEST REGION ENGINEERING SERVICES	SCALE AS..SHOWN	DATE JAN.10/05	
	DWN. BY BCD	CHKD. BY KCB	DWG. No. 1002
			REV. 0

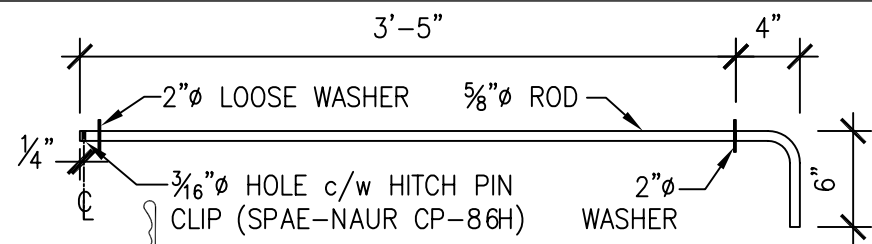

1003-1 ITEM #13
PARTITION LOCK PIN

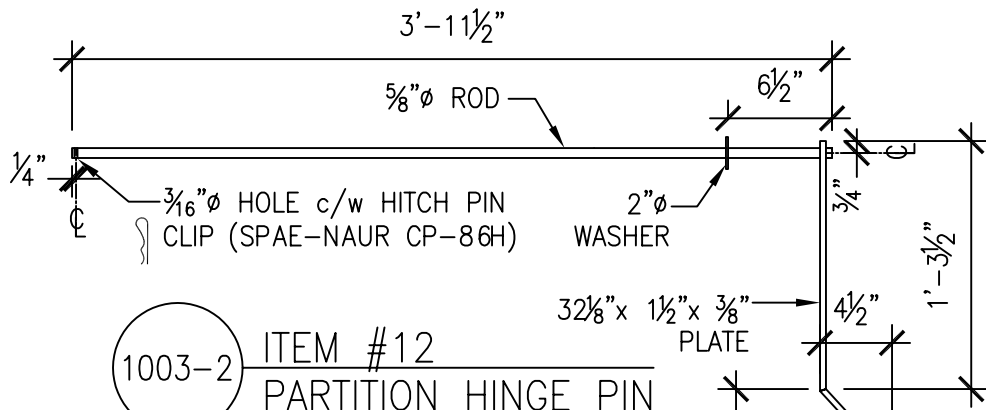

1003-2 ITEM #12
PARTITION HINGE PIN

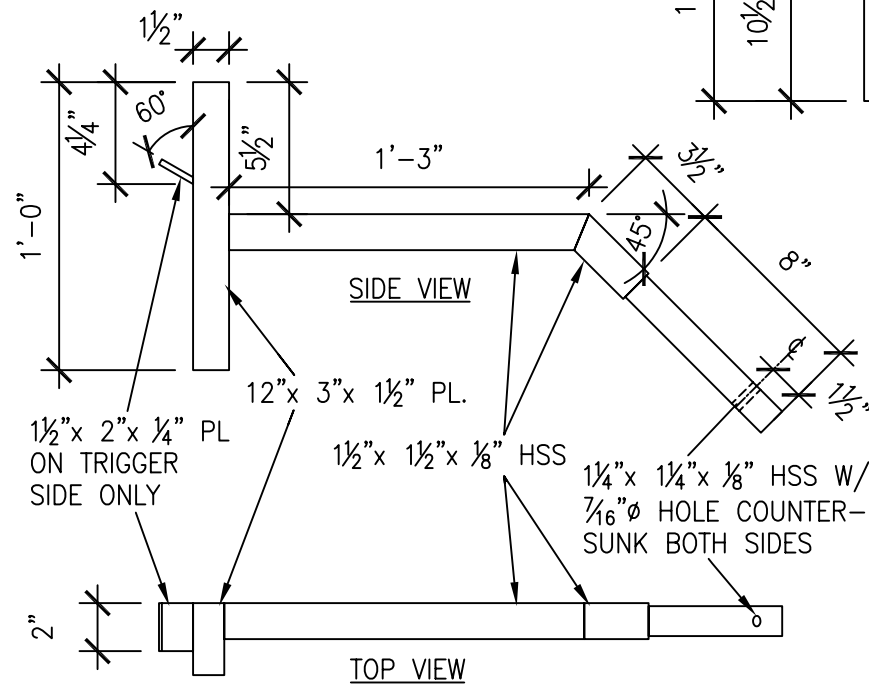

1003-3 ITEM #16
WEIGHTED ARM

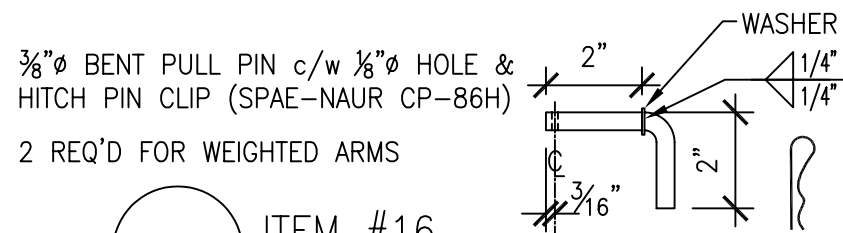

2 REQ'D FOR WEIGHTED ARMS

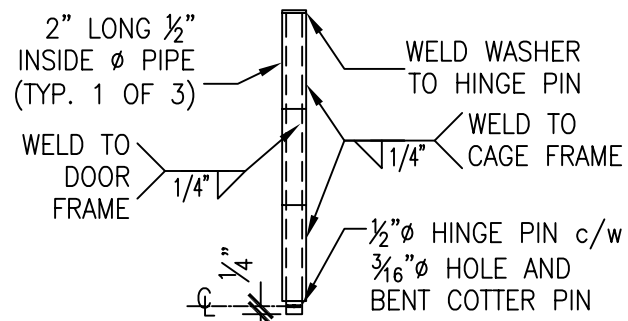

1003-4 ITEM #7
HINGES

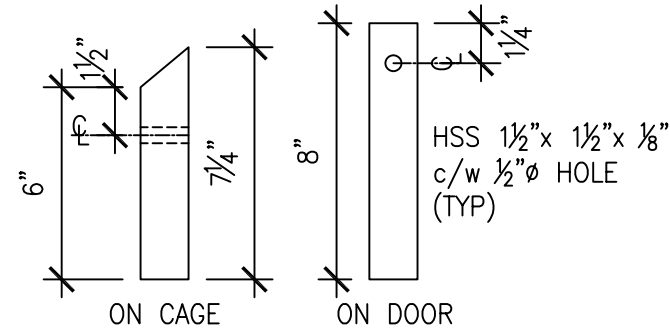

1003-5 ITEM #17
WEIGHTED ARM HOLDERS

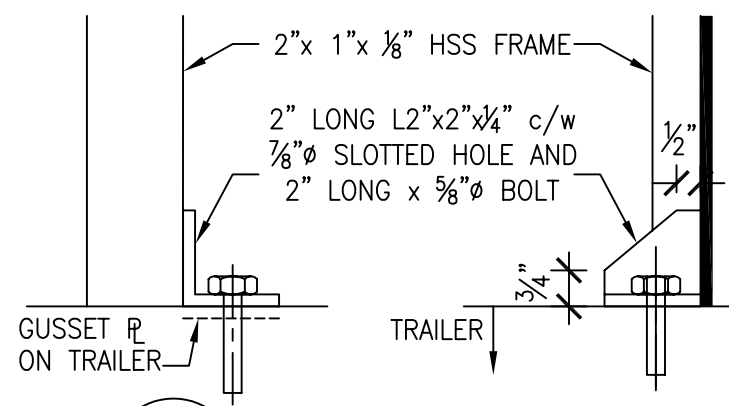

1003-6 ITEM #26
TRAILER BOLT DOWNS

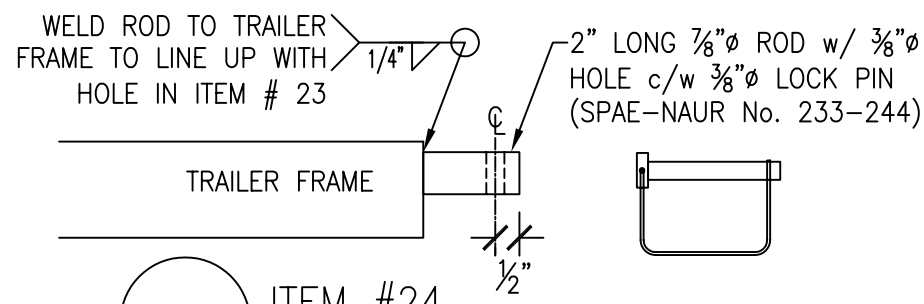

1003-7 ITEM #24
LOCK ROD

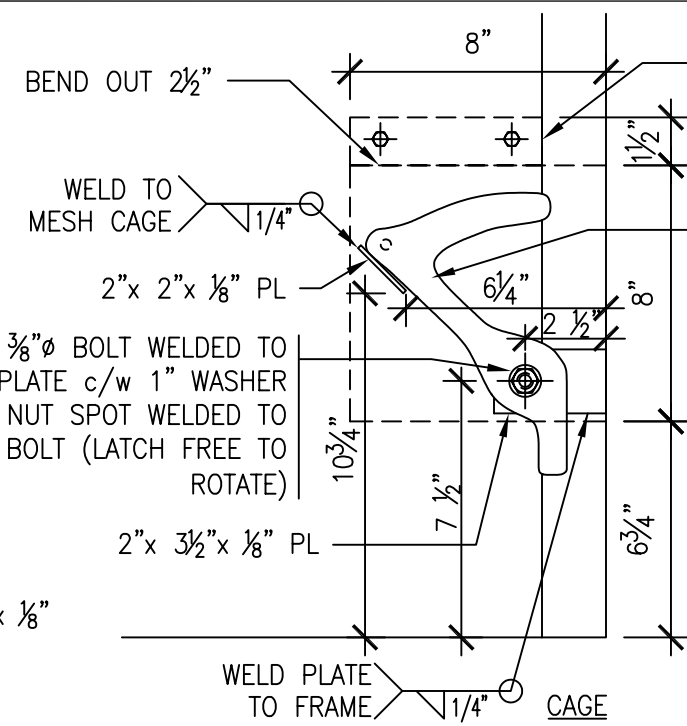

1003-8 ITEM #22
LATCH

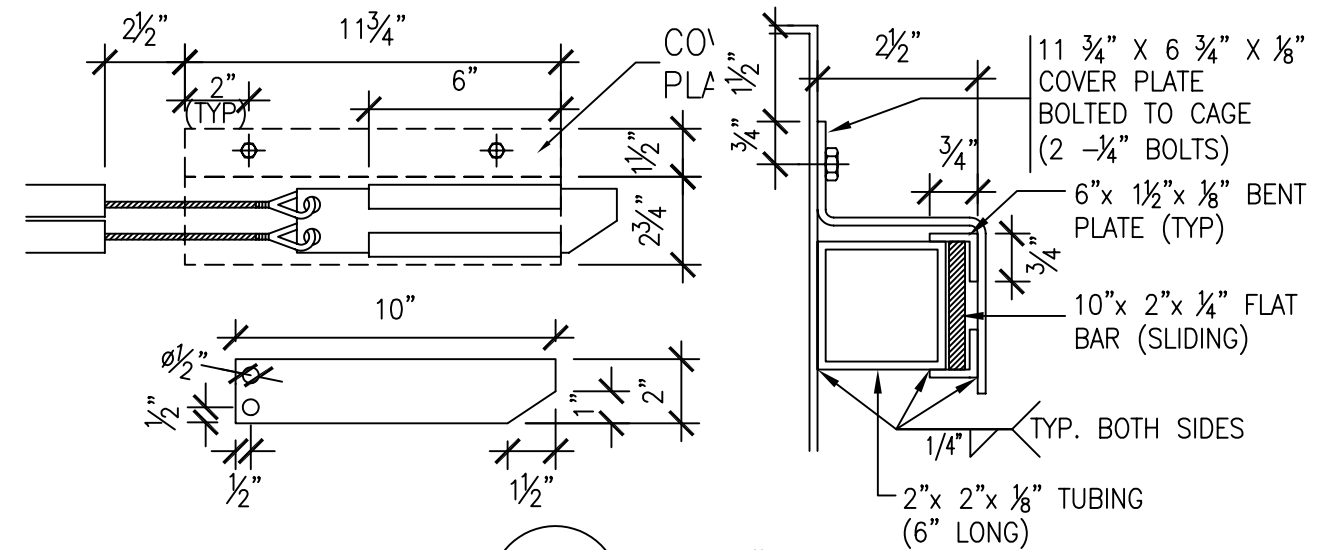
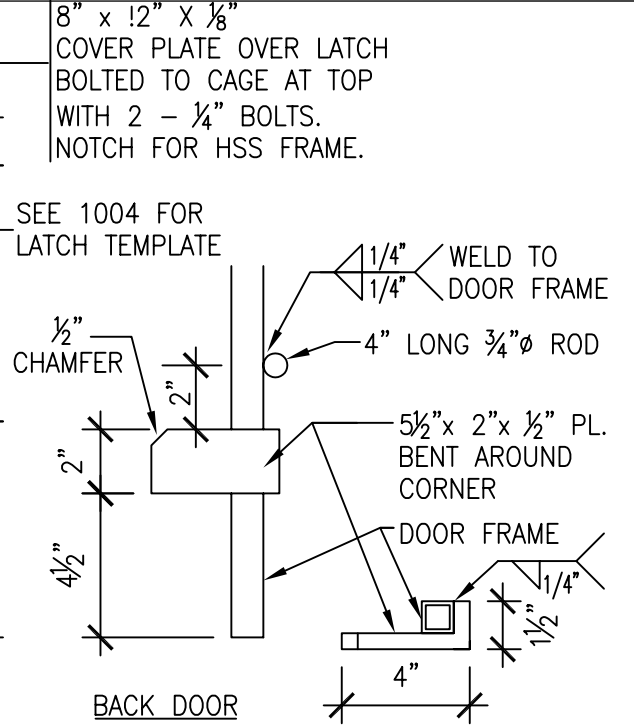

1003-9 ITEM #18
TRIGGER



Ministry of
Natural
Resources

NORTHWEST REGION
ENGINEERING SERVICES

PROJECT CAMBRIAN DESIGN BEAR TRAP	
DRAWING TITLE DETAILS	
SCALE N.T.S.	DATE JAN.10/05
DWN. BY BCD	CHKD. BY KCB
DWG. No. 1003	REV. 0

No.	ITEM	DESCRIPTION	QTY.
1	CAGE TOP AND BOTTOM	4'x 8' STEEL PLATE w/ 4" BENDS ALONG EACH LENGTH. 14 GAUGE TOP PLATE, 12 GAUGE BOTTOM.	2
2	CAGE SIDES	39"x 8'-0" PIECE OF 1/2" #13 F FLAT EXPANDED MESH	2
3	JAB HOLES	1/2" LONG x 2"Ø PIPE	12
4	CAGE FRAMES	3 SIDED 40"x 40" (INS.) FRAME MADE FROM 2"x 1"x 1/8" HSS	3
5	FRONT & BACK DOOR FRAMES	40 3/4"Hx 42"W (OUT.) FRAME w/ VERTICAL CENTER SUPPORT MADE FROM 1"x 1"x 1/8" HSS	2
6	FRONT & BACK DOOR MESH	40 1/4"W x 42"H PIECE OF 1/2" #13 F FLAT EXPANDED MESH	2
7	PIPE HINGES	SEE DETIAL 1003-4	6
8	HINGE LOCK ROD	1/2"Ø ROD (APPROX 3'-2" LONG) w/ 3" BEND AT TOP (TO FIT LOSELY IN HINGES c/w 1/8" HOLE & CLEVIS PIN)	1
9	DOOR HANDLE	9" LONG x 3/8"Ø ROD w/ BEND AT MIDPOINT	1
10	PARTITION DOOR FRAME	37 3/4"x 37 3/4" (OUT.) 1"x 1"x 1/8" HSS FRAME w/ HORIZONTAL 1"x 2"x 1/8" HSS CENTER SUPPORT	1
11	PARTITION DOOR MESH	37 3/4"x 37 3/4" PIECE OF 1/2" #13 F FLAT EXPANDED MESH	1
12	PARTITION HINGE PIN	SEE DETAIL 1003-2	1
13	PARTITION LOCK PIN	SEE DETAIL 1003-1	1
14	PARTITION DOOR SIDE PLATE	3"x 2"x 1/4" PLATE w/ 3/4"Ø HOLE (C OF HOLE 1" FROM END)	2
15	PARTITION PIN HOLES	3/4"Ø HOLE w/ 2"Ø WASHER AROUND HOLE WELDED TO CAGE	6
16	WEIGHTED ARM	SEE DETAIL 1003-3	2
17	WEIGHTED ARM HOLDERS	SEE DETAIL 1003-5	4
18	TRIGGER	SEE DETAIL 1003-9	1
19	TRIGGER CABLE	3/16" BRAIDED STEEL CABLE WITH EYELET EACH END (1 PIECE APPROX. 7'-9" LG, 1 PIECE APPROX. 4'-7" LG)	2
20	TRIGGER SLEEVE	1"Ø STEEL PIPE (1 PIECE APPROX. 7'-3" LG, 1 PIECE APPROX. 4'-1" LG)	2
21	SHIM	3" LONG 1"x 1"x 1/8" HSS	1
22	LATCH	SEE DETAIL 1003-8	2
23	LOCK PLATE	3"x 2"x 1/4" PLATE w/ 1 1/4" Ø HOLE	1
24	LOCK ROD	SEE DETAIL 1003-7	1
25	LIFTING HANDLES	3" LONG x 1"Ø PIPE WELDED TO TOP CORNERS OF CENTER CAGE FRAME	2
26	TRAILER BOLT DOWNS	SEE DETAIL 1003-6	6

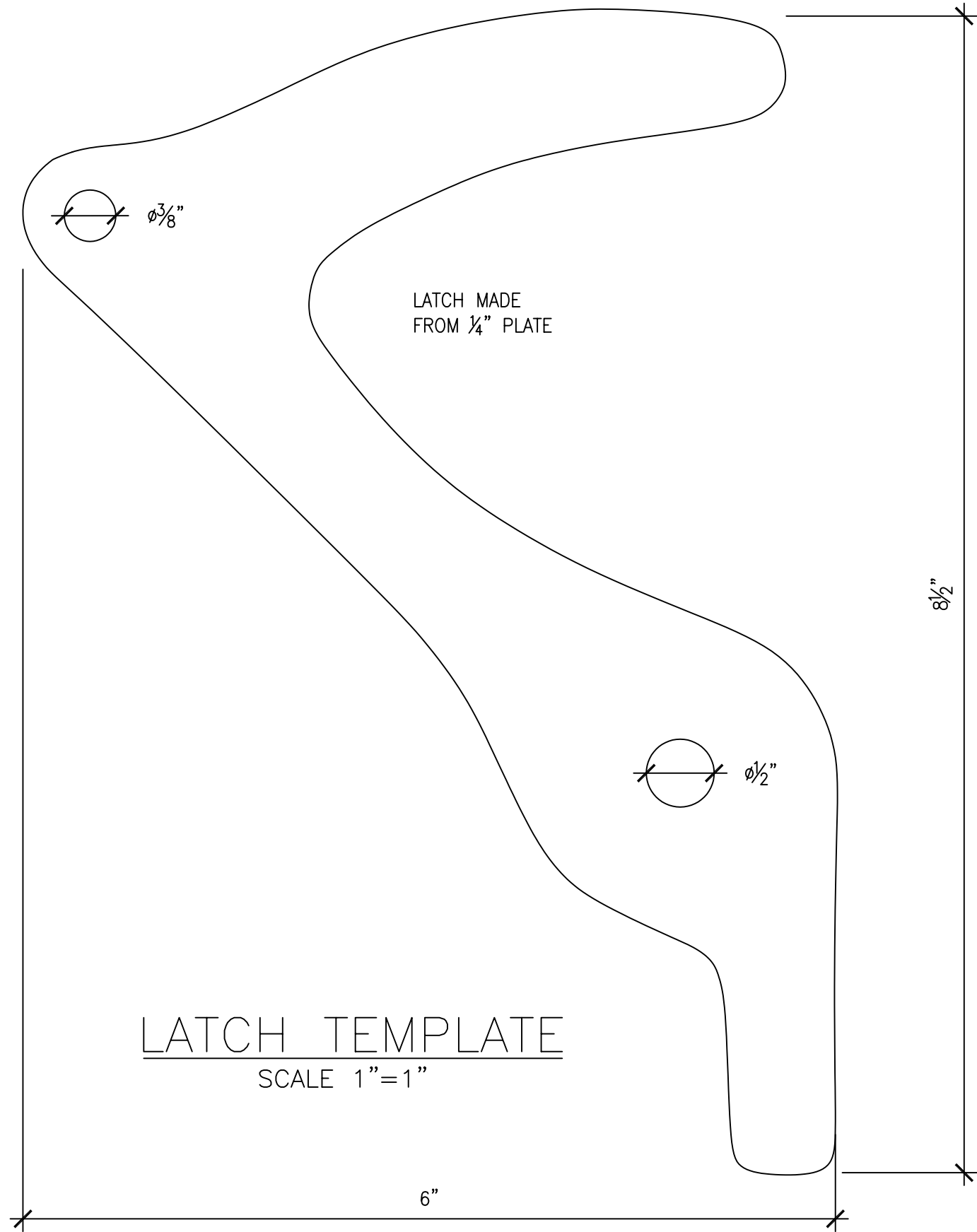

LATCH TEMPLATE
SCALE 1"=1"

 Ministry of Natural Resources	PROJECT CAMBRIAN DESIGN BEAR TRAP	
	DRAWING TITLE LATCH TEMPLATE & ITEM No. DESCRIPTIONS	
NORTHWEST REGION ENGINEERING SERVICES	SCALE 1"=1"	DATE JAN.10/05
	DWN. BY BCD	CHKD. BY KCB
DWG. No. 1004		REV. 0